

The Aharonov-Bohm Effect and Its Applications to Superconducting Flux Line Observation?

Akira Tonomura

Advanced Research Lab., Hitachi, Ltd., Hatoyama, Saitama 350-03, Japan

(Received July 12, 1992)

The Aharonov-Bohm effect is experimentally confirmed to exist under ideal conditions where there is no overlap between an incident electron wave and a confined magnetic field. The experiment not only establishes the physical reality of gauge fields but also opens up a new way, based on the principle behind this effect, to observe microscopic flux lines.

I. INTRODUCTION

The Aharonov-Bohm (AB) effect* is a production of the phase shift between two electron waves enclosing a magnetic flux even when the waves do not touch the magnetic flux. Such a situation is inconceivable in classical electrodynamics, since electrons are not acted on by any force and, consequently, experience no physical influence. The significance of this effect is increased in relation to the gauge theory, originally formulated by Yang and Mills² in 1954 and rediscovered in the 1970s, since the AB effect is regarded as direct evidence substantiating the existence of gauge fields, or vector potentials.³

An attempt to assist in solving the controversy concerning the AB effect was made using two advanced techniques, i.e., electron holography⁴ and microlithography. The infinitely long solenoid proposed by Aharonov and Bohm was not experimentally attainable. Therefore, a very small toroidal ferromagnet covered with a superconducting layer to completely confine the magnetic field was employed using the Meissner effect which arrangement was proposed by Yang.⁵ Electron holography was used to test the existence of a non-zero phase shift between two electron waves passing inside the hole and outside the toroid.⁶

II. AB EFFECT EXPERIMENTS

A series of experiments tested the AB effect. The first experiment reported in 1982 employed transparent toroidal ferromagnets.⁷ The toroidal sample shown in Fig. 1(a) has a completed magnetic circuit. Only a low degree of magnetic flux leaks from the magnet, but this

[†] Invited paper presented at the International Symposium in Honor of Professor C. N. Yang's 70th Birthday, July 10-11, 1992, National TsingHua University, Hsinchu, Taiwan, R.O.C.

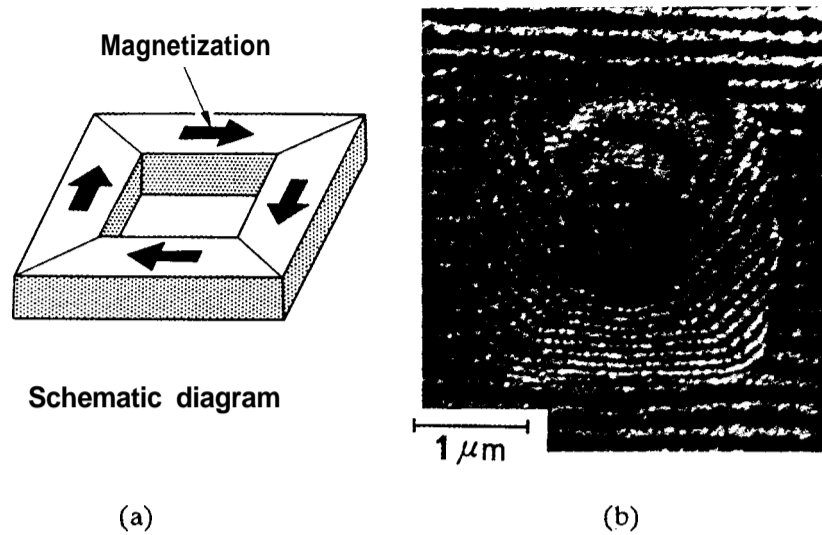

FIG. 1. Experimental test of the AB effect using a transparent toroidal ferromagnet. (a) Schematic of sample. (b) Interferogram.

can be quantitatively measured by interference electron microscopy⁴ to confirm the non-effect on the experimental conclusion. The interferogram shown in Fig. 1 (b) is the interference pattern between the electron wave transmitted through the toroid and a tilted plane wave. If there is no phase shift, interference fringes should be along straight lines inside and outside the toroid. The resultant interferogram indicates that a relative phase shift of 12π is produced.

It was asserted that the existence of the AB effect was established.⁷ However, Bocchieri, et al., contended in their papers⁷ that the detected phase shift was not a consequence of the AB effect but of the Lorentz force, and that the AB effect should be tested under conditions where there is no overlap between an electron wave and a magnetic field.

Two further experiments were made, one to prevent electron penetration into a magnet⁷ and another to investigate the possible quantization of magnetic flux in a toroidal ferromagnet.¹⁰ The last decisive experiment⁶ proposed by Yang⁷ is introduced in detail in the following.

Very tiny toroidal ferromagnets completely covered with superconducting Nb layers were fabricated using state-of-the-art photolithographic techniques (Fig. 2). An electron wave incident around a sample and the relative phase shift between two electron waves passing inside and outside the toroid were measured by means of an interferogram formed by electron holography. In this case, the absolute value of the phase shift could not be measured but a fraction of the phase shift modulo 2π could be.

Although samples with various magnetic flux values were measured, the relative phase shifts detected were either 0 or π as shown in Fig. 3. The conclusion is now obvious. A relative phase shift of $n\pi$ (see Fig. 3 (b)) is produced even when the magnetic fields are confined within

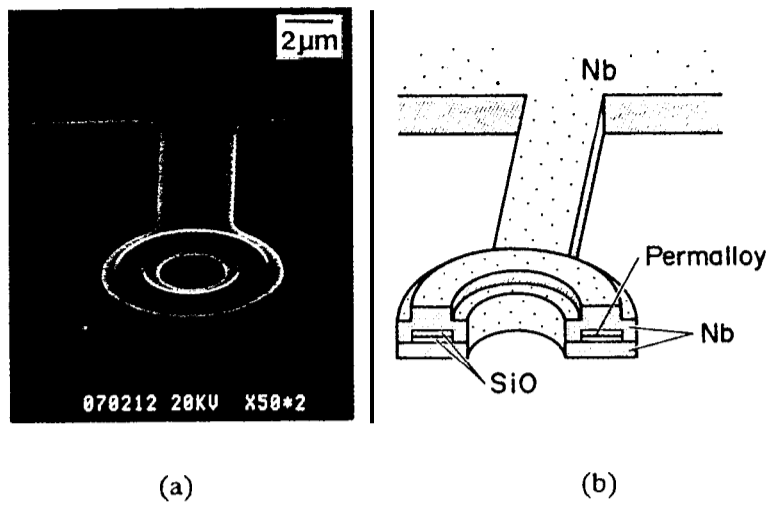

FIG. 2. Tiny toroidal ferromagnet. (a) Scanning electron micrograph. (b) Cross-sectional view.

the superconductor and thus shielded from the electron wave. This conclusively proves that the AB effect exists.

The fact that a phase shift takes a quantized value of either 0 or π provides the key evidence that the magnetic field is completely surrounded, and consequently shielded, by the superconductor.

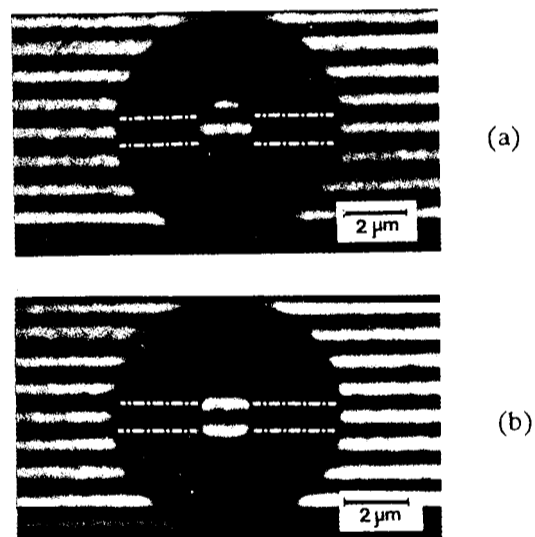

FIG. 3. Experimental test of the AB effect using toroidal ferromagnets covered with superconductors
(a) Phase shift = 0. (b) Phase shift = π .

III. FLUX LINE OBSERVATION

Magnetic flux is quantized in the smallest unit of flux $h/2e$ when it is completely surrounded by a superconductor. This flux quantization was experimentally discovered in 1961 by Deaver and Fairbank¹¹ and by Doll and Näbauer,¹² and theoretically interpreted by Byers and Yang.¹³ Byers and Yang revealed that flux quantization in $h/2e$ flux units requires no new physics but indicates the pairing of electrons in a superconductor.

Although quantized flux, or flux lines, has proven to play an important role in the fundamental properties and practical uses of superconductors, flux lines have evaded direct observation. This is because, in addition to being extremely small, $h/2e$ ($= 2 \times 10^{-15}$ Wb), flux lines are shaped like very thin threads,

Electron holography based on the AB effect has made it possible to directly and quantitatively observe magnetic lines of force as contour lines in the transmitted wavefront.⁴ An example is shown in Fig. 4. This sample is a fine cobalt particle.¹⁴ The particle is shaped like a triangular pyramid truncated parallel to the base plane (see Fig. 4 (a)). When it is observed by electron microscopy, only its outline can be observed. In interference micrograph (b), however, many contour fringes appear. Contour fringes parallel to the three edges indicate that the thickness increases up to 500 Å. Circular fringes in the inner region show magnetic lines of force directly in h/e flux units. Magnetic flux flow inside such fine particles can be easily observed.

The next example is of observing flux lines penetrating a superconducting thin film.¹⁵

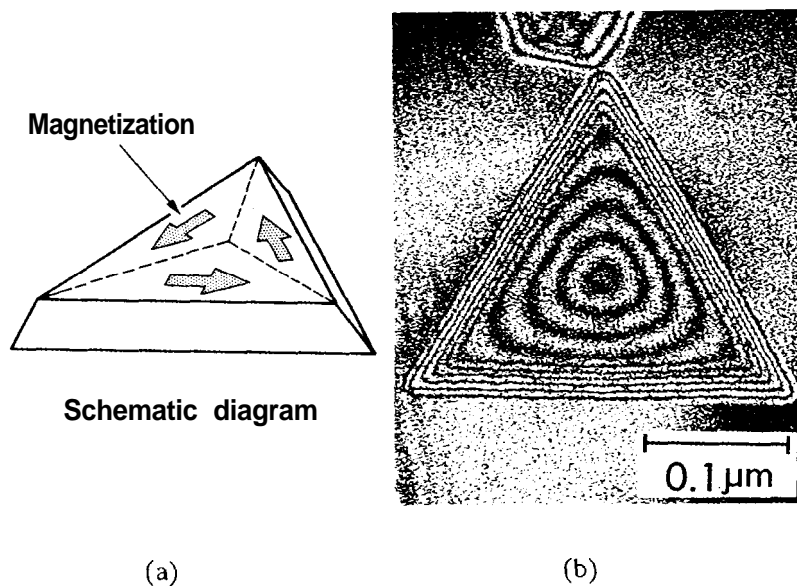

FIG. 4. Interference electron micrograph of a fine cobalt particle. (a) Schematic of sample. (b) Contour map.



FIG. 5. Interference electron micrographs of flux lines penetrating superconducting Pb films (phase amplification: X 2). (a) Thickness = $0.2 \mu\text{m}$. (b) Thickness = $1 \mu\text{m}$.

Figure 5(a) shows the single flux line observed when a superconductive film was $0.2 \mu\text{m}$ thick. In this figure, the phase difference is amplified by a factor of two. One interference fringe, therefore, corresponds to a flux line. A single flux line is captured in the right side of this photograph. The magnetic line of force is produced from an extremely small area of lead surface, $0.15 \mu\text{m}$ in diameter, then spread out into free space. In addition to the isolated flux line, a pair of flux lines oriented in opposite directions and connected by magnetic lines of force were also observed (Fig. 5 left).

What happens when the superconducting thin film thickens? Figure 5(b) shows the state of the magnetic lines of force when the thickness is $1 \mu\text{m}$. The state is completely changed and magnetic flux penetrates the superconductor in a bundle instead of individually. The figure does not show any flux line pairs. The explanation of this phenomenon is that because lead is a type-1 superconductor, a strong magnetic field applied to it partially destroys the superconductive state in some parts of the specimen. This intermediate state is shown in Fig. 5(b) where the magnetic lines of force are seen to penetrate the parts of the specimen where superconductivity is destroyed. However, because the surrounding parts are still superconductive, the total degree of penetrating magnetic flux is an integral multiple of the $h/2e$ flux quantum.

Figure 5(a) was an exception in which the lead film behaved like a type-II superconductor and the flux penetrated the superconductor in the form of individual flux quanta.

Since the flux itself can now be observed, even dynamic observation is possible.¹⁶

IV. CONCLUSION

The wave nature of electrons first proposed as a purely imaginary assumption by de Broglie, has become usable in observing fundamentals of quantum mechanics and microscopic

objects and fields through holography since an electron interference pattern can be observed directly on a fluorescent screen by the development of a "Coherent" field-emission electron beam.

Individual flux lines penetrating a superconducting thin film have become observable even in real-time. In the near future, it will become possible to observe a flux lattice with a 350-kV holography electron microscope.

Note added *in proof*. A flux lattice in a Nb superconducting film has recently been observed in real time.¹⁷

REFERENCES

1. Y. Aharonov and D. Bohm, Phys. Rev., **D** 115,485, (1959), See also M. Peshkin and A. Tonomura, *The Aharonov-Bohm Effect*, Lecture Notes in Physics, Vol. 340, (Springer, New York, 1989).
2. C. N. Yang and R. L. Mills, Phys. Rev., **101**, 1597 (1956).
3. T. T. Wu and C. N. Yang, Phys. Rev., **D** 12, 3845 (1975);.
4. A. Tonomura, Physics Today, 22, (April 1990), See also A. Tonomura, Rev. Mod. Phys., 59,639 (1987).
5. C. N. Yang, Proc. Intern. Symp. on Foundations of Quantum Mechanics, Tokyo, 1983 (Physical Society of Japan, Tokyo, 1984) p. 27.
6. A. Tonomura, et al., Phys. Rev. Lett., 56,792 (1986).
7. A. Tonomura, et al., Phys. Rev. Lett., 48, 1443 (1982).
8. P. Bocchieri, et al., Lett. Nuovo Cimento, 53,370 (1982).
9. A. Tonomura, et al., Proc. Intern. Symp. Foundations of Quantum Mechanics, Tokyo, 1983, (Physical Society of Japan, Tokyo, 1984) p. 20.
10. A. Tonomura, et al., Phys. Rev. Lett., 51,331 (1983).
11. B. S. Deaver and W. M. Fairbank, Phys. Rev. Lett., 7, 43 (1961).
12. R. Doll and M. N abauer, Phys. Rev. Lett., 7, 51 (1961).
13. N. Byers and C. N. Yang, Phys. Rev. Lett., 7, 46 (1961).
14. A. Tonomura, et al., Phys. Rev. Lett., 44, 1430 (1980).
15. T. Matsuda, et al., Phys. Rev. Lett., 62, 2519 (1989).
16. T. Matsuda, et al., Phys. Rev. Lett., 66, 457 (1991).
17. K. Harada et al., Nature, 360, 51 (1992).